

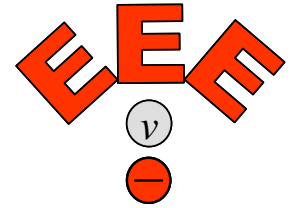

UCC

Coláiste na hOllscoile Corcaigh, Éire
University College Cork, Ireland



Electronic Lens (E-lens) based Medical Imaging and Microscopy

By
Nabeel A. Riza

School of Engineering
University College Cork (UCC), Ireland
Email: n.riza@ucc.ie <http://soe.ucc.ie>

The Research Area is also called :

- **Bio-Photonics**
- **Medical Optics**

What is the General Optical Imaging Scenario ?



A Possible Model-

A Communications Perspective

Transmitter (T)

Receiver (R)

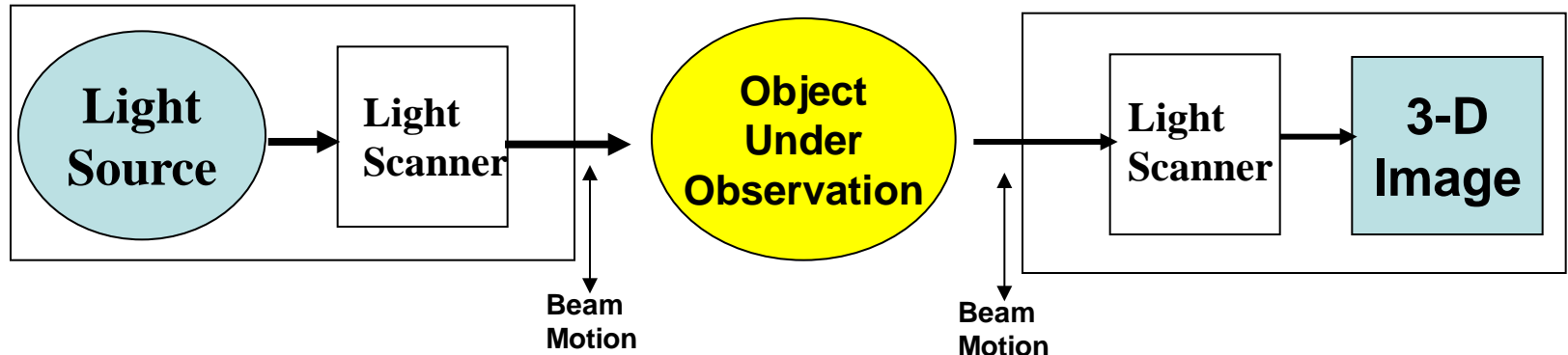

Objects:

Macro-Scale: Aircrafts

Micro-scale: Blood Vessels, Cancer Cells

Nano-scale: DNA Structures

Light Travel Distances:

Macro-Scale: Kilometers (Radar)

Micro-scale: < Millimeter (Microscopy)

Nano-Scale: < Micrometer (Nanoscopy)

THE COMMON FACTOR --- THE LIGHT SCANNER

AN ULTIMATE CHALLENGE IN HEALTH OPTICS – ENDOSCOPIC IMAGING

Application: Early Lung Cancer Detection (Highest Deaths from Lung Cancer)

X-Ray CT

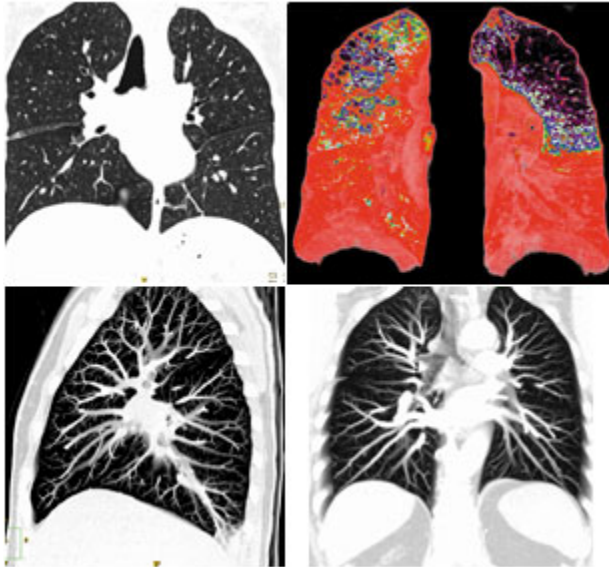

www.shscentre.com/serLung.html

Achieve The Following Basic Endoscope Attributes:

- Deep Guided Access through Lung Air Passages
- High Resolution Non-Destructive Imaging

↓
A Solution *
↓

**Use a Laser Carrier in Single Mode Fiber in Combination with
Ultra-Compact 3-D Beamformer Chip**

* S. A. Khan and N. A. Riza, Confocal microscopy based agile optical endoscope using liquid crystals, IEEE LEOS BioPhotonics Topical Meeting, paper MA4.2, San Diego June 28, 2004.

Basic Confocal Microscope- Eliminate Sample/Slide Motion

The Problem: Slide/Sample or objective axial motion in confocal microscopy can be coupled with fluidic mechanical forces that perturb the sample and measurement.

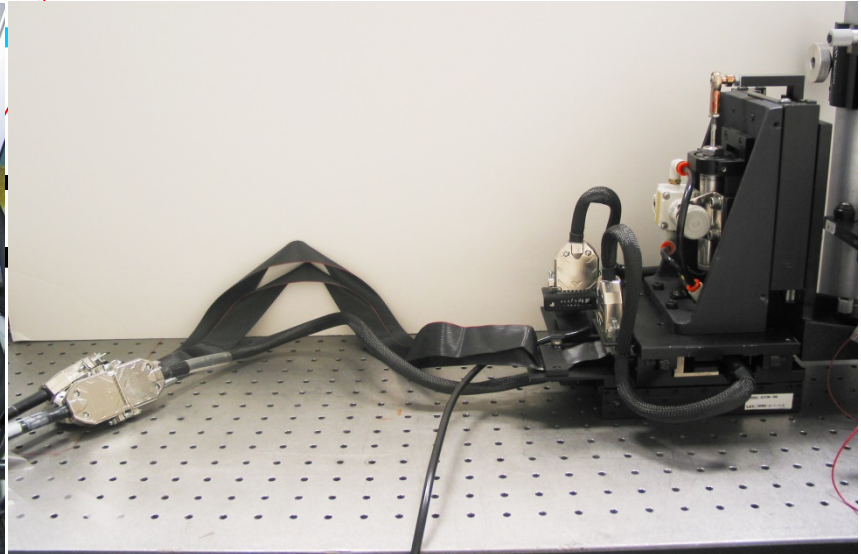
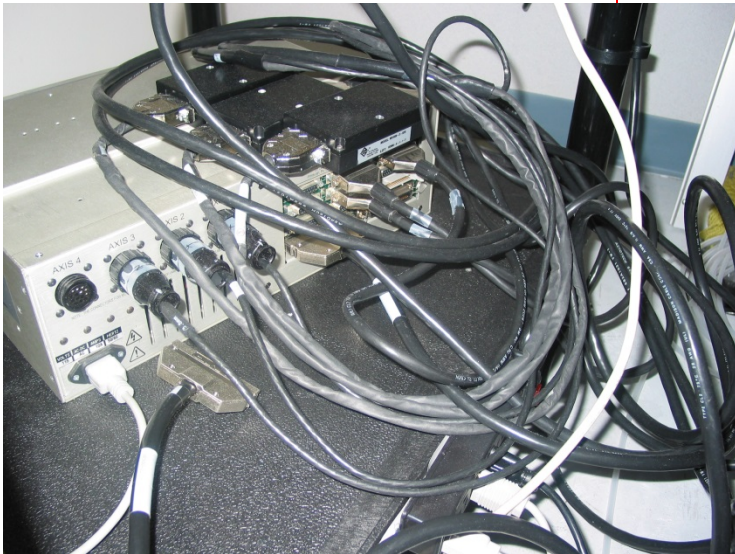
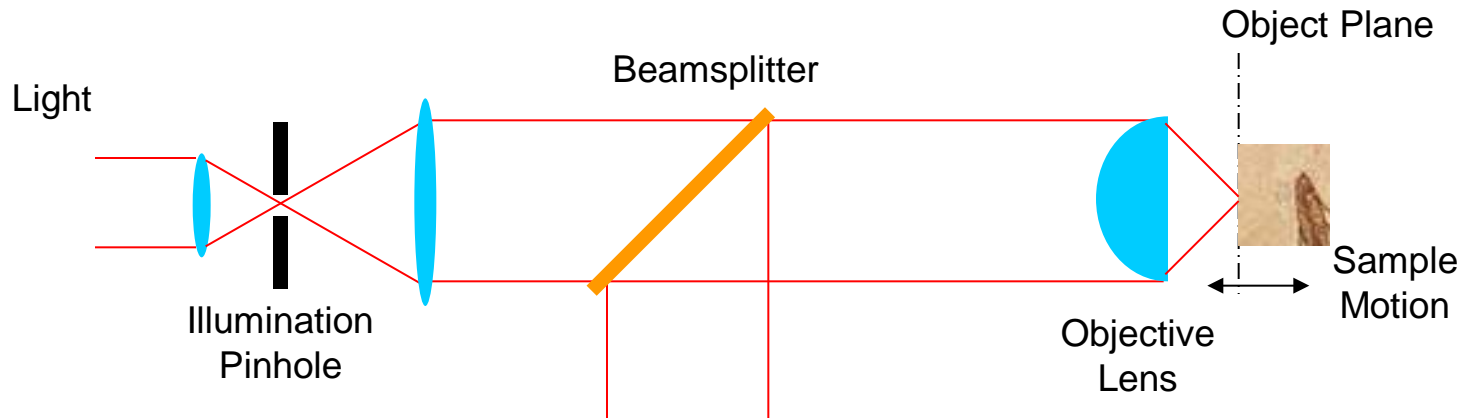

ULTIMATE SCANNER OBJECTIVE (Holy Grail):

8-Point Motion/Detection of Light-The Basic Element – Voxel of Volumetric Scanning-Imaging

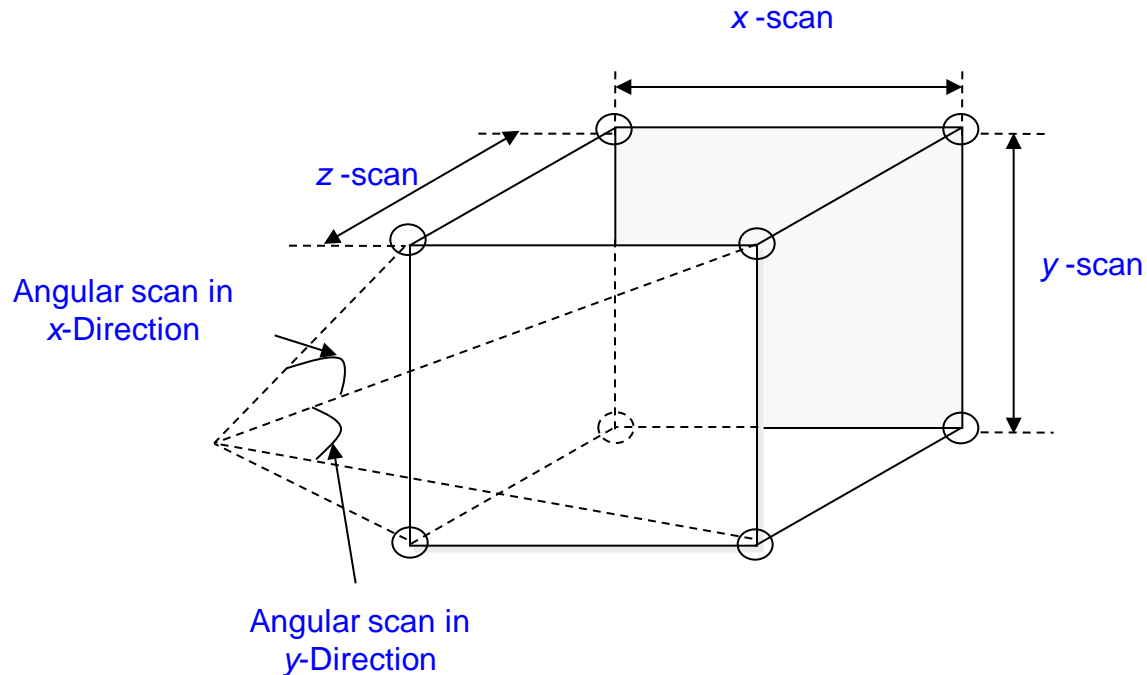

Need Fine Power as Well as High Power Scan Capability

Full Programmability Polarization-Multiplexed Optical Scanner (Single VOXEL Scan Design)

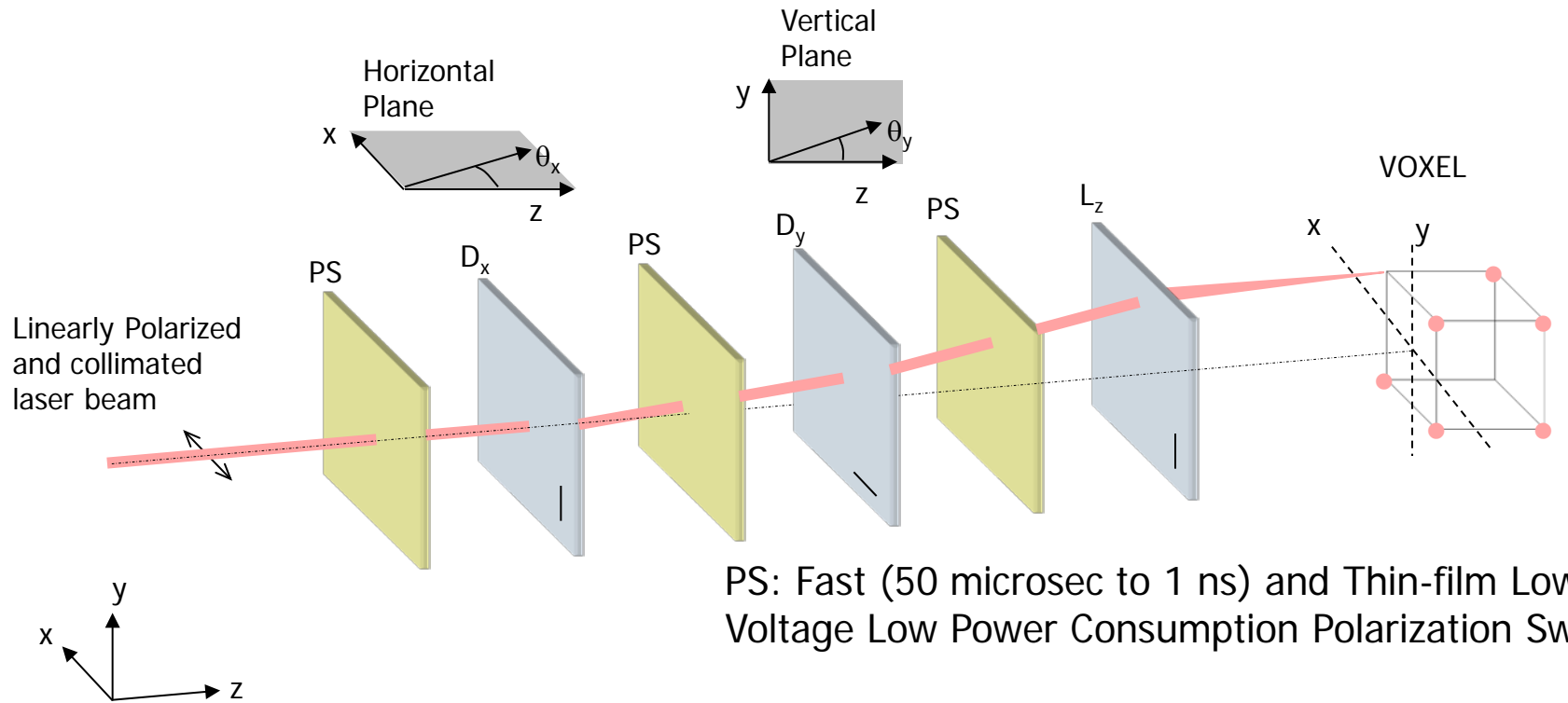

PS: Fast (50 microsec to 1 ns) and Thin-film Low Voltage Low Power Consumption Polarization Switch

D: Electrically Reconfigurable Non-Pixelated Birefringent Beam Deflector Device

L: Electrically Reconfigurable Non-Pixelated Birefringent Lens Device

N. A. Riza, OSA Top. Mtg., Proc. SPIE, **3482**, 572, 1998.

N. A. Riza, US Patent 6,031,658, 2000.

Pixel-Free Deflector Structure and Working Principle

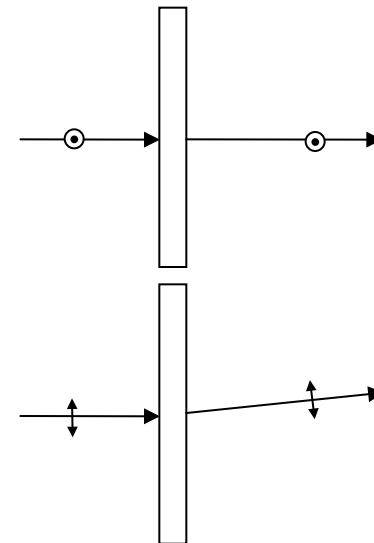
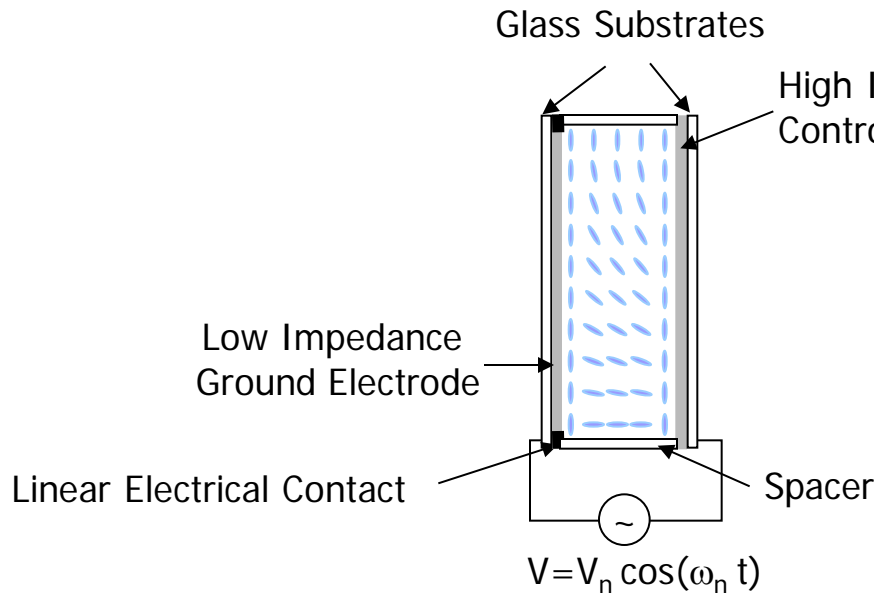
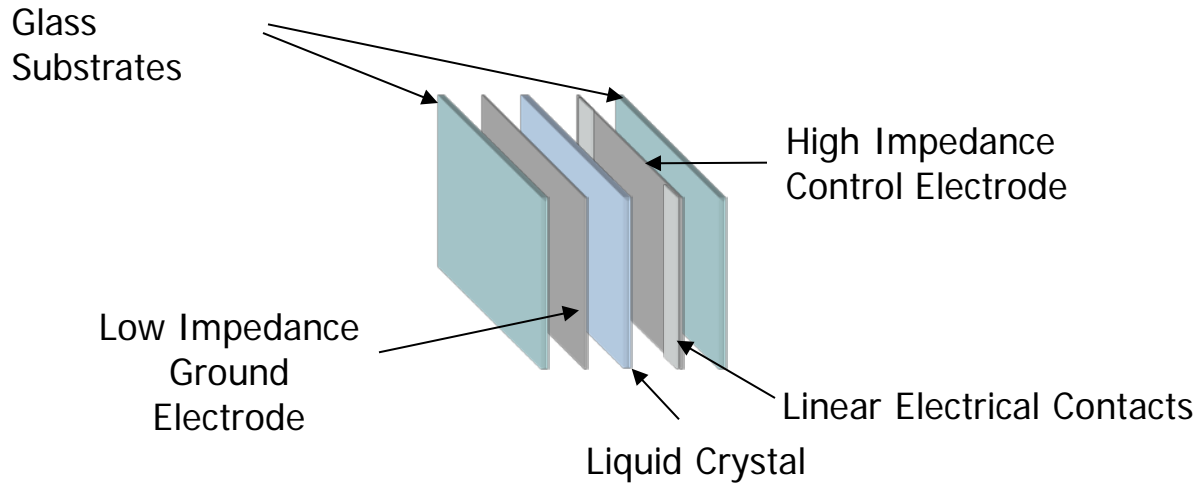

Pixel-Free Lens Working Principle

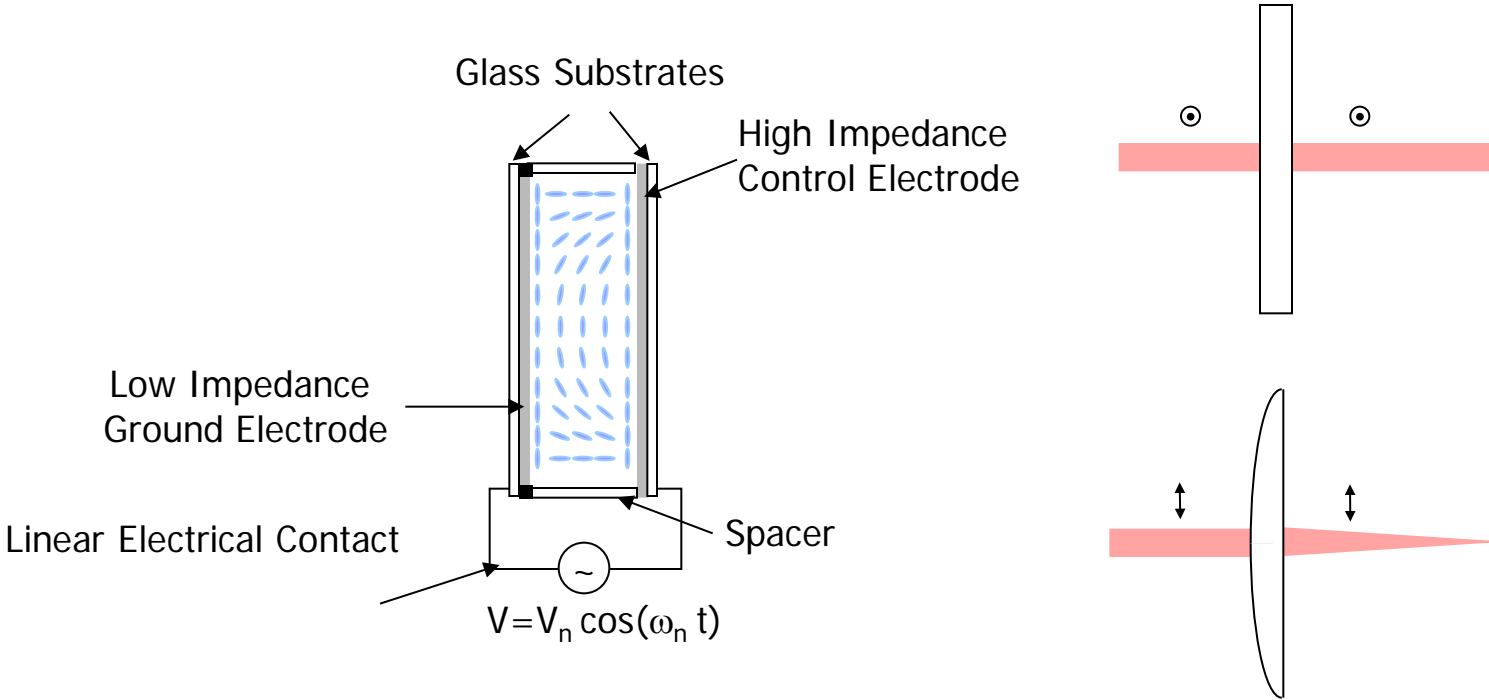

1-D Coarse-Fine Scan Module

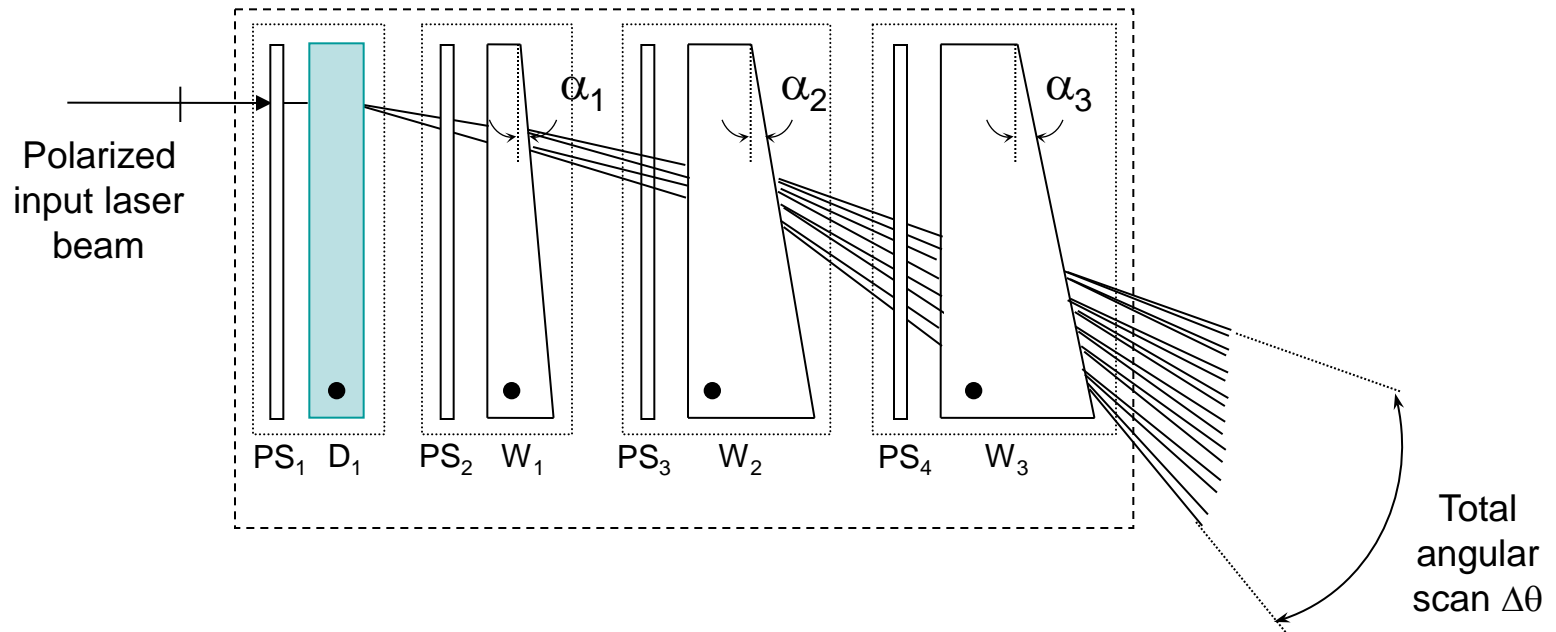

Three Birefringent Wedges, four Polarization Switches and one NLC deflector used.
Total scan addressability: $2^4 = 16$ discrete points plus Continuous Scan Between Points

The Fine Stage Corrects for the Non-Uniform Scan Operation of the Digital Coarse Stage

W: Bulk Birefringent Wedge
PS: Polarization Switch
D: NLC deflector

1-D Coarse-Fine Demonstration

Direct Viewing By CCD

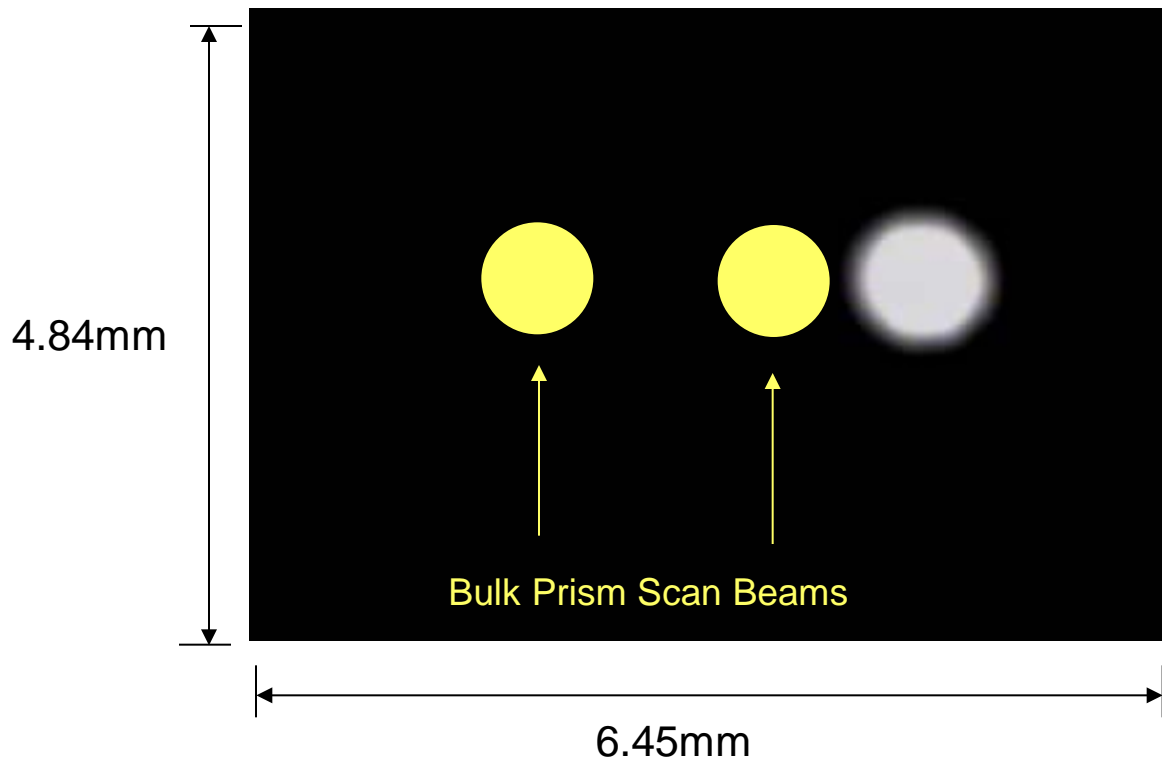

Number of FLC Polarization Switches used: 2
Number of NLC (Merck BL006) Deflectors used: 1
Number of Bulk Prism (Rutile) Wedges used: 1
 $\lambda = 1.55\mu\text{m}$

1-D 4-Bit Coarse Only Discrete Scan PMOS Analysis: 33.11° Scan

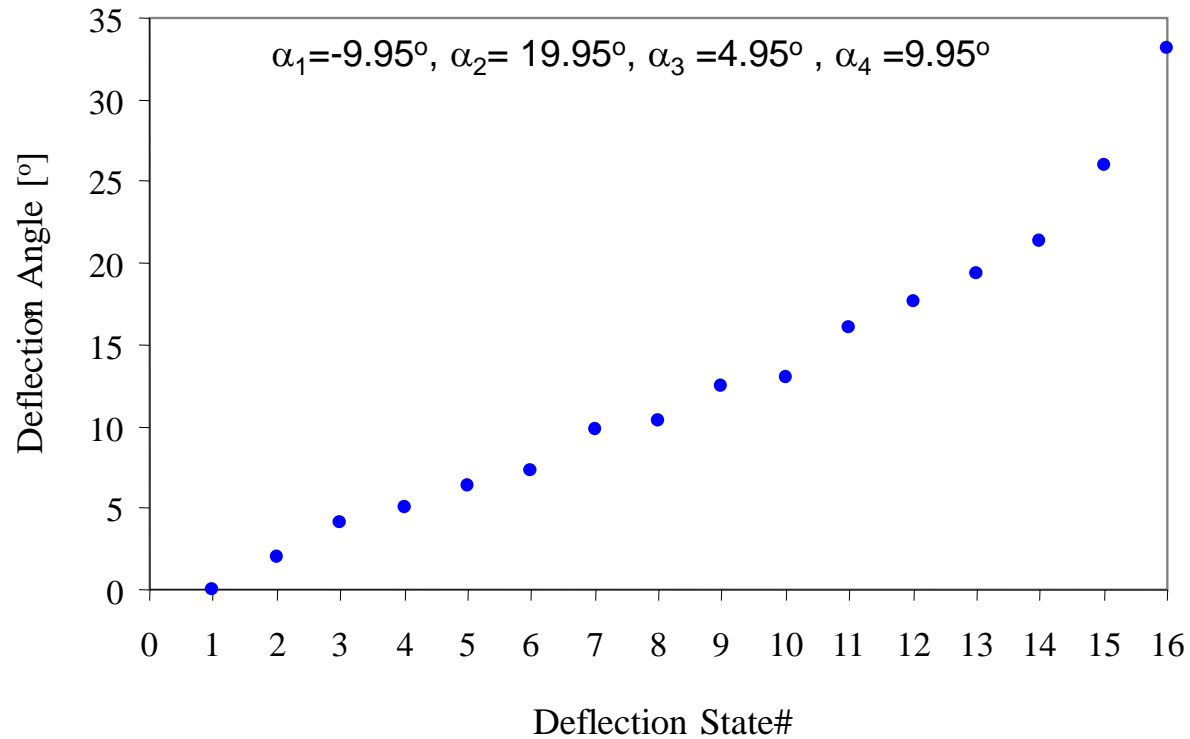

α_n : Apex Angle for nth stage

2-D Coarse Scan P-MOS Module

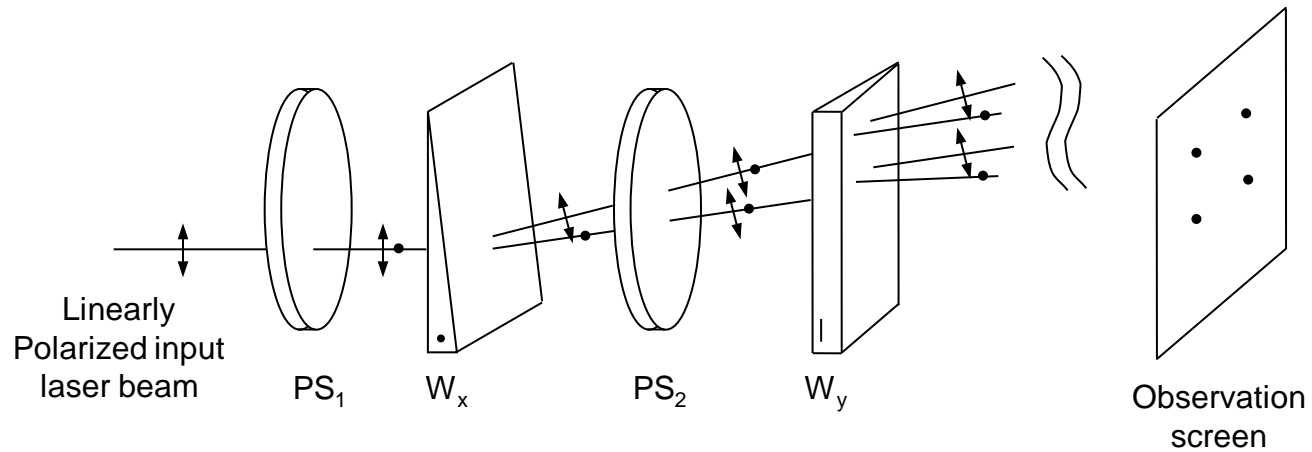

W: Bulk Birefringent Wedge

PS: Polarization Switch

2-D 4-Bit Coarse-Fine Demonstration

Direct Viewing By CCD

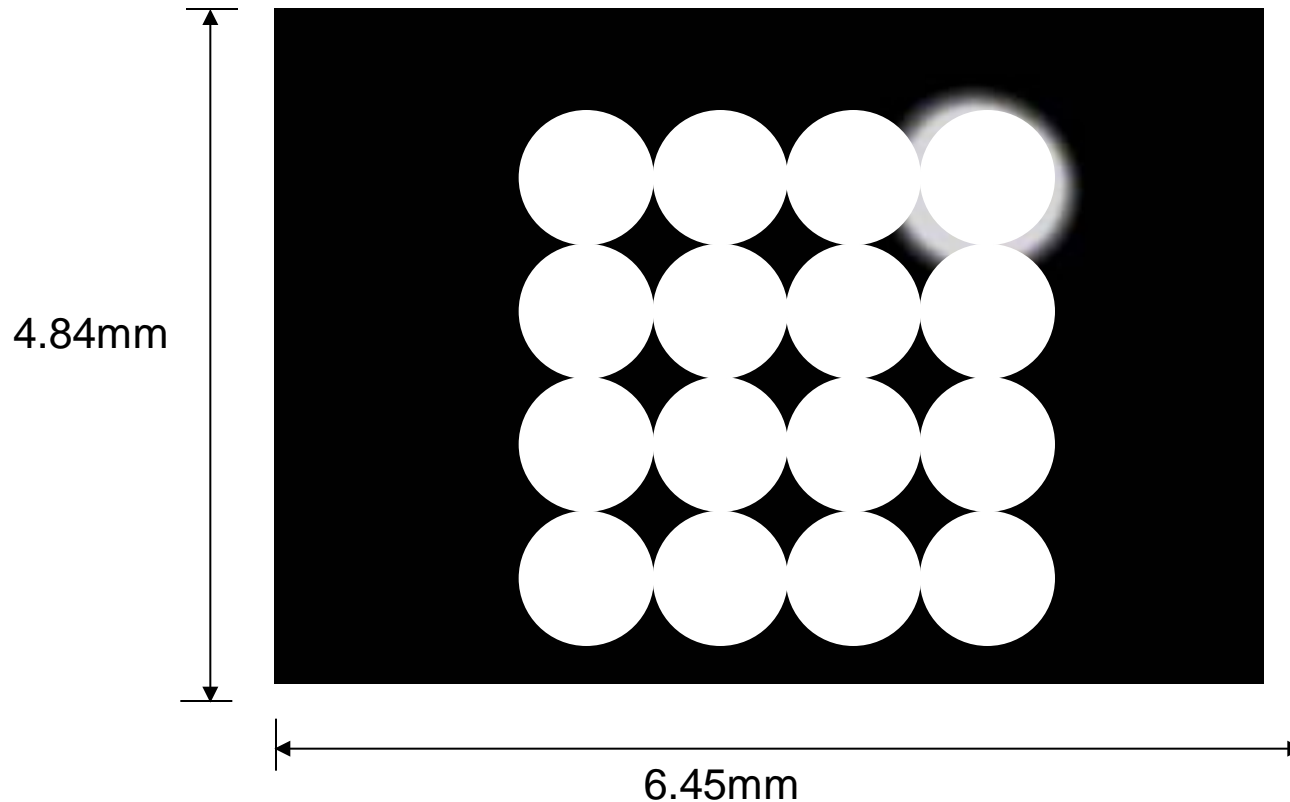

Number of FLC Polarization Switches used: 4
Number of NLC (Merck BL006) Deflectors used: 2
Number of Bulk Prism (Rutile) Wedges used: 2
 $\lambda = 1.55\mu\text{m}$

3-D 2-Bit Coarse Only + 1-Bit Longitudinal Fine Scanning PMOS Demonstration

Direct Viewing By CCD

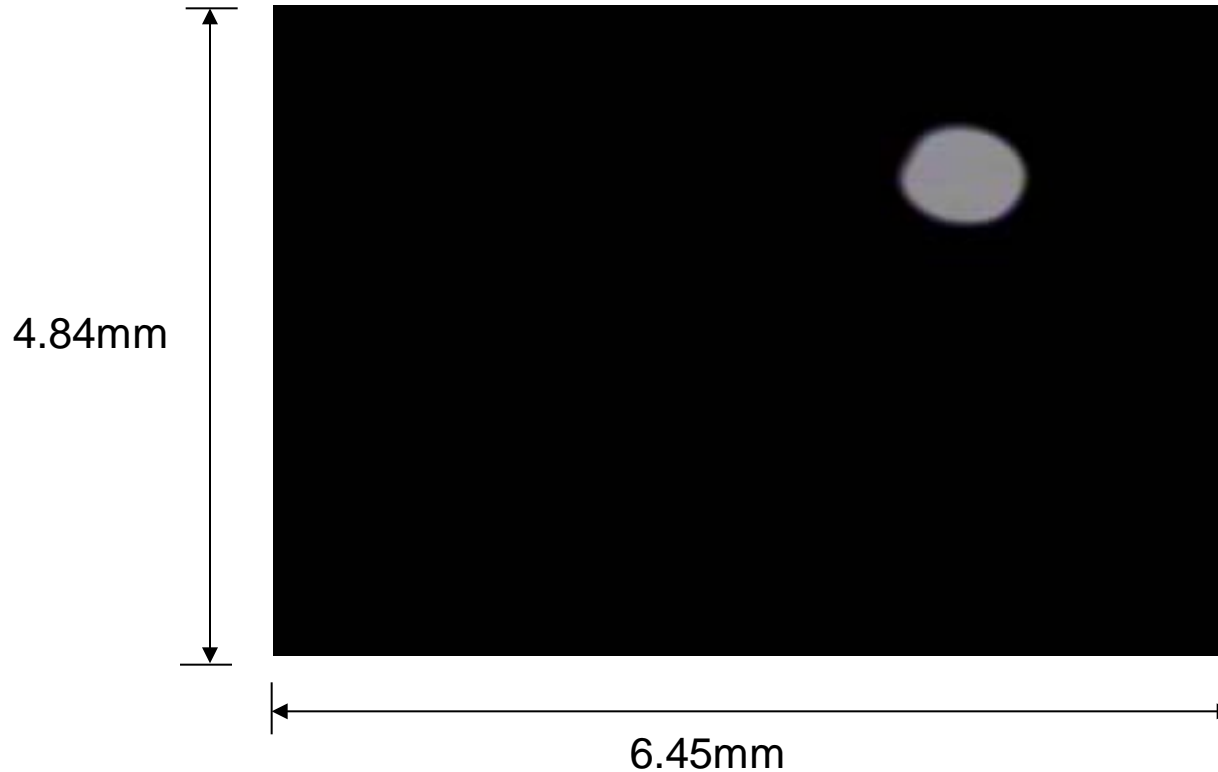

Number of FLC Polarization Switches used: 3
Number of NLC (Merck BL006) Lenses used: 1
Number of Bulk Prism (Rutile) Wedges used: 2
 $\lambda = 1.55\mu\text{m}$

PROPOSED ENDOSCOPIC PROBE DESIGNS USING OPTICAL CHIPS

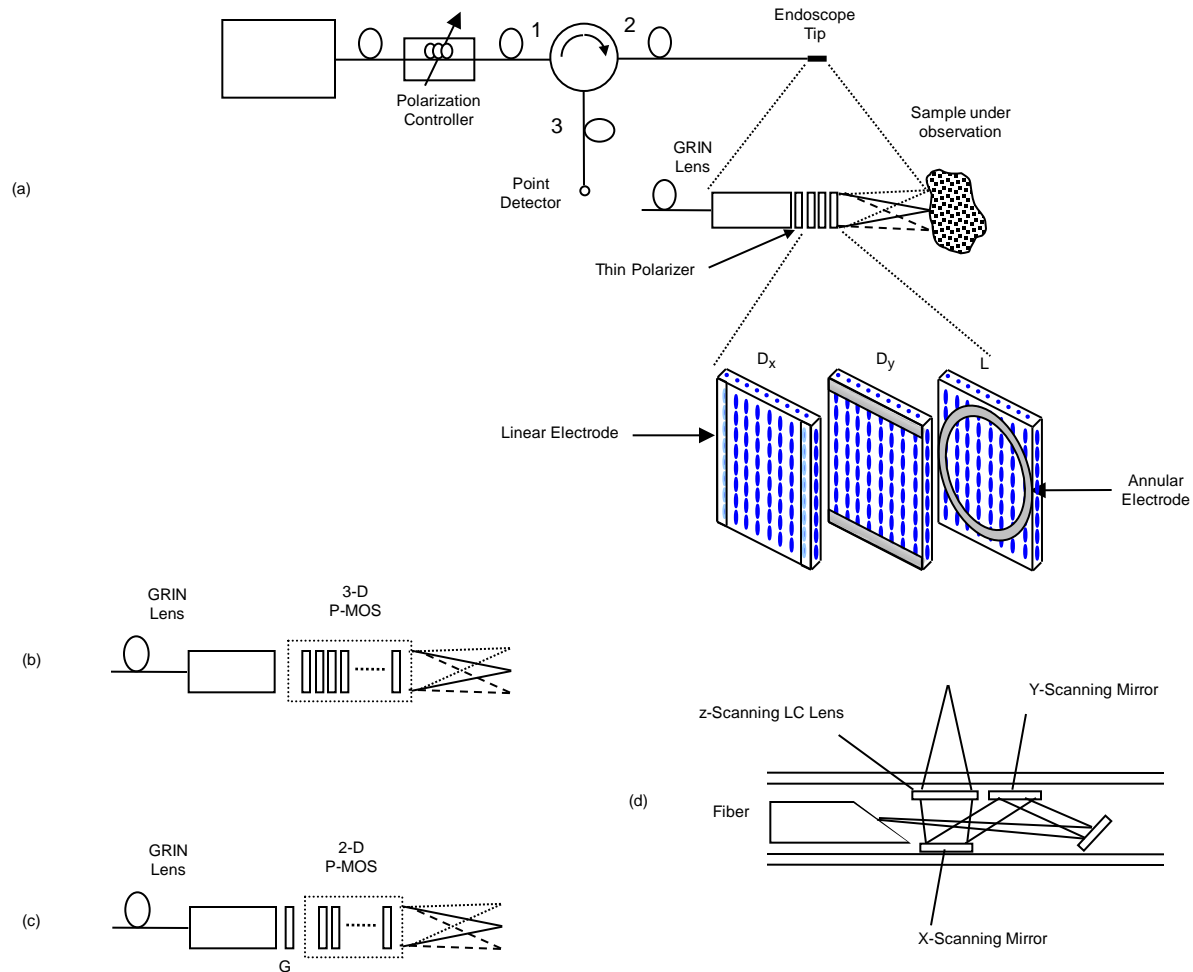

* S. A. Khan and N. A. Riza, Confocal microscopy based agile optical endoscope using liquid crystals, IEEE LEOS BioPhotonics Topical Meeting, paper MA4.2, San Diego June 28, 2004.

LC Based Confocal Microscope Architecture

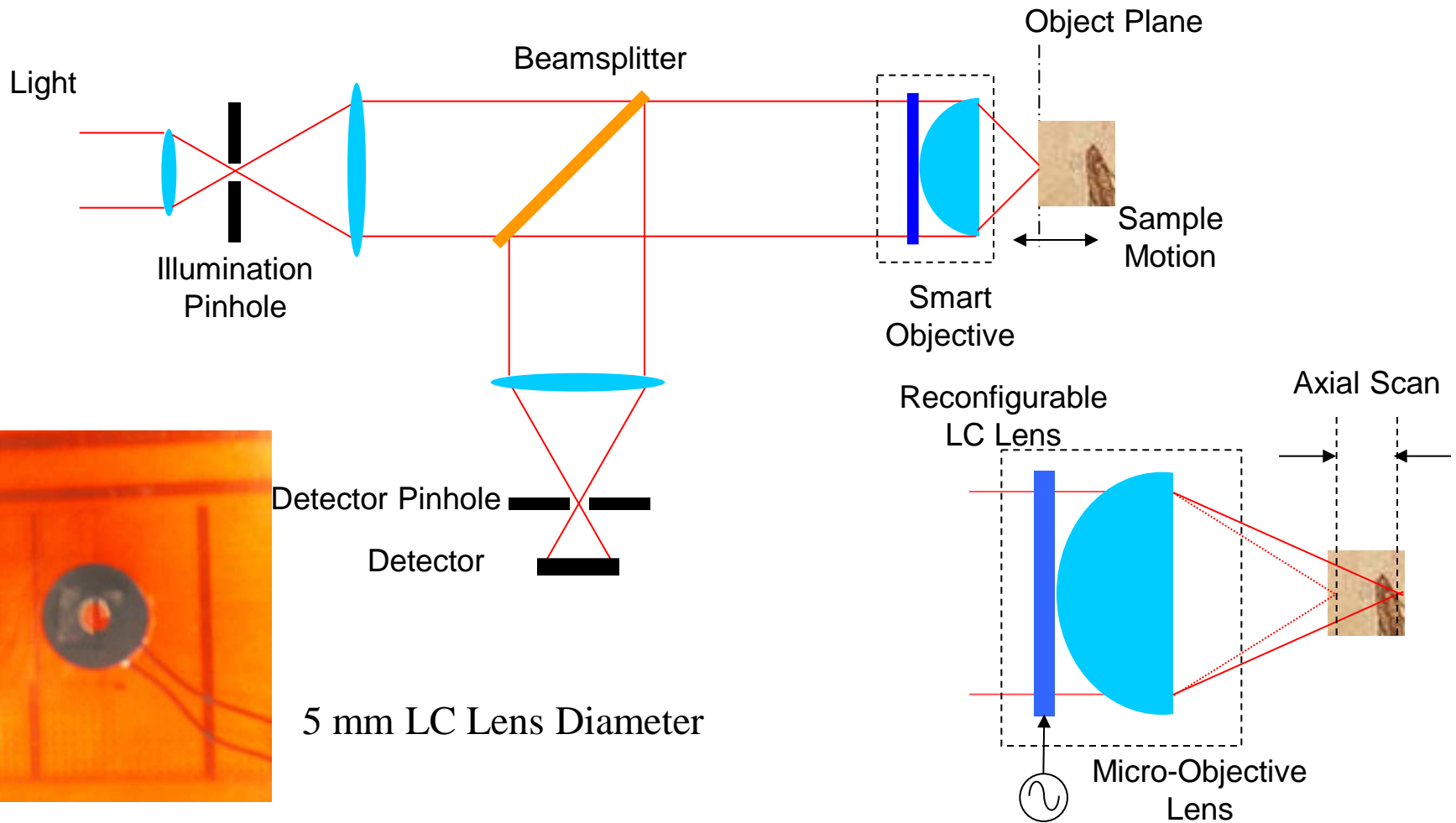

N. A. Riza and S. A. Khan, "Programmable High Speed Polarization Multiplexed Optical Scanner", Optics Letters, vol. 28, Issue 7, 2003.

N. Riza and A. Bokhari, "Agile Optical Confocal Microscopy Instrument Architectures For High Flexibility Imaging," SPIE Biomedical Optics, 2004, 24-29 Jan, 2004, San Jose, CA.

Experimental Setup

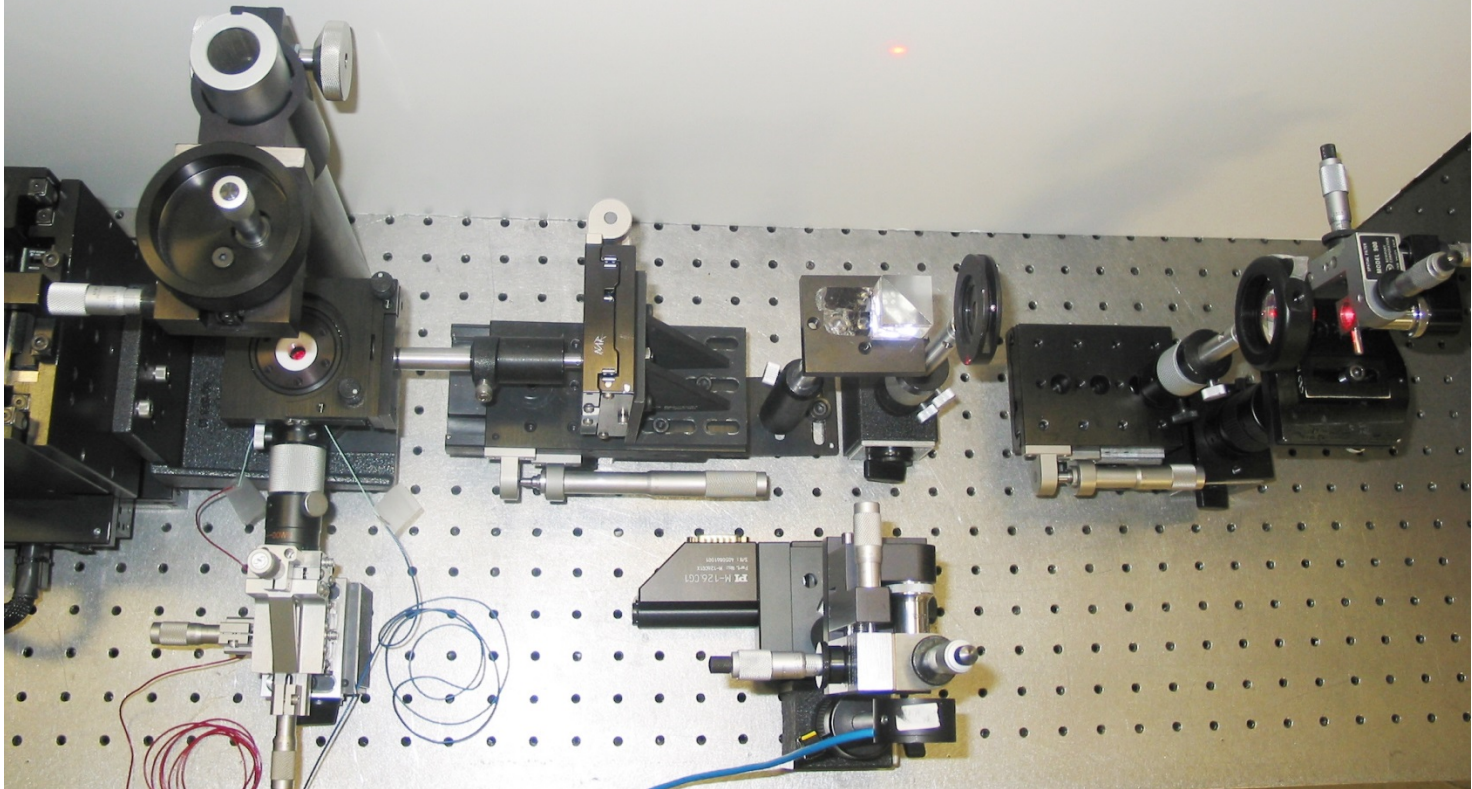

Measured axial resolution of the microscope

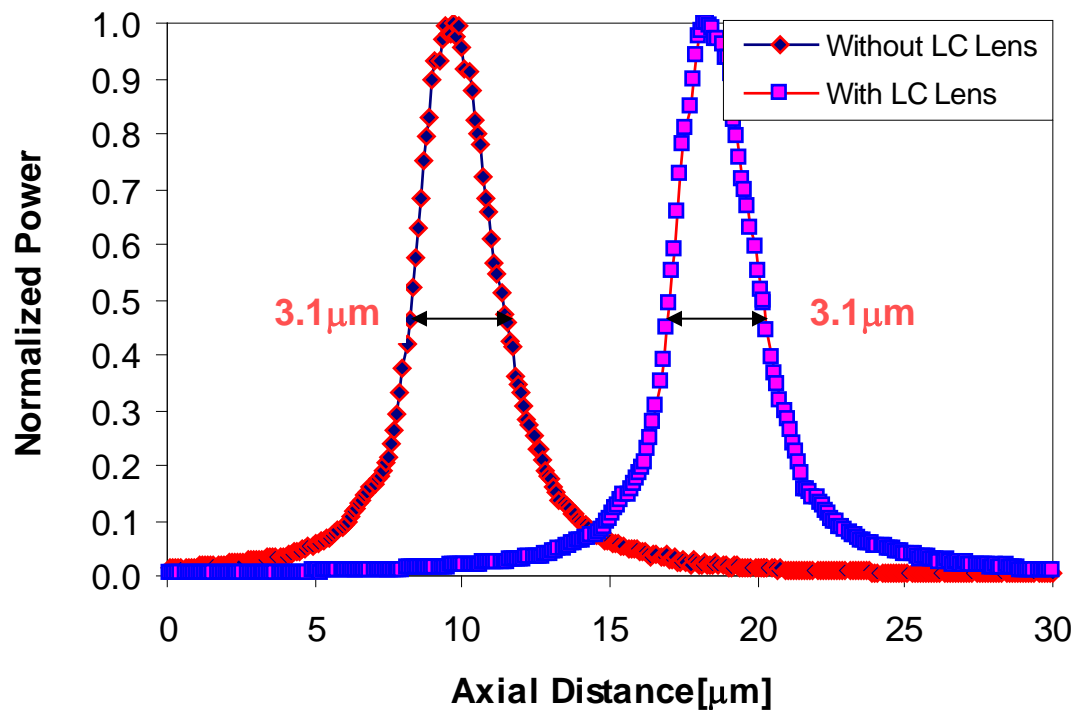

LC Lens dia=5mm
LC Lens thickness=50μm
Micro-objective NA=0.65
LC Lens Applied Voltage=4.8V_{Pk}
square wave at 2.4 kHz

Demonstrated axial scanning transfer characteristics

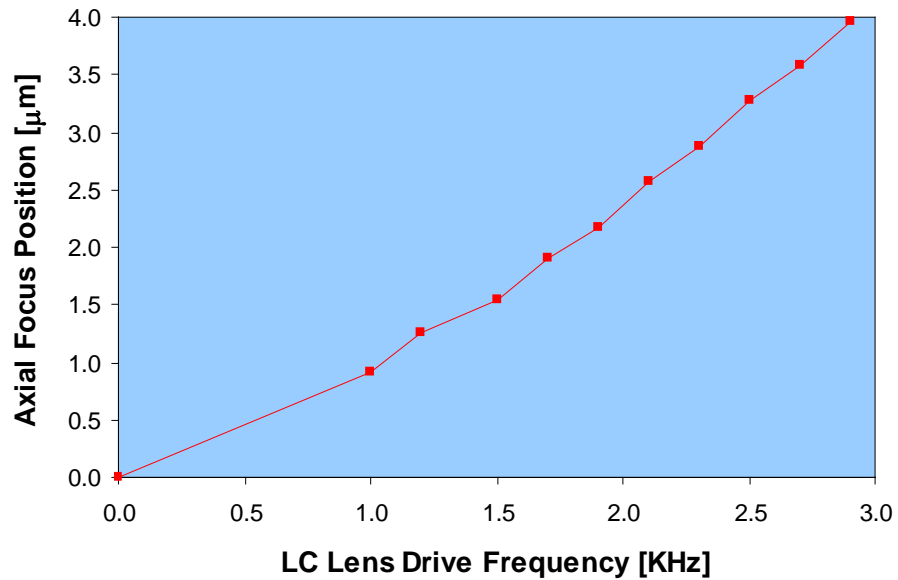
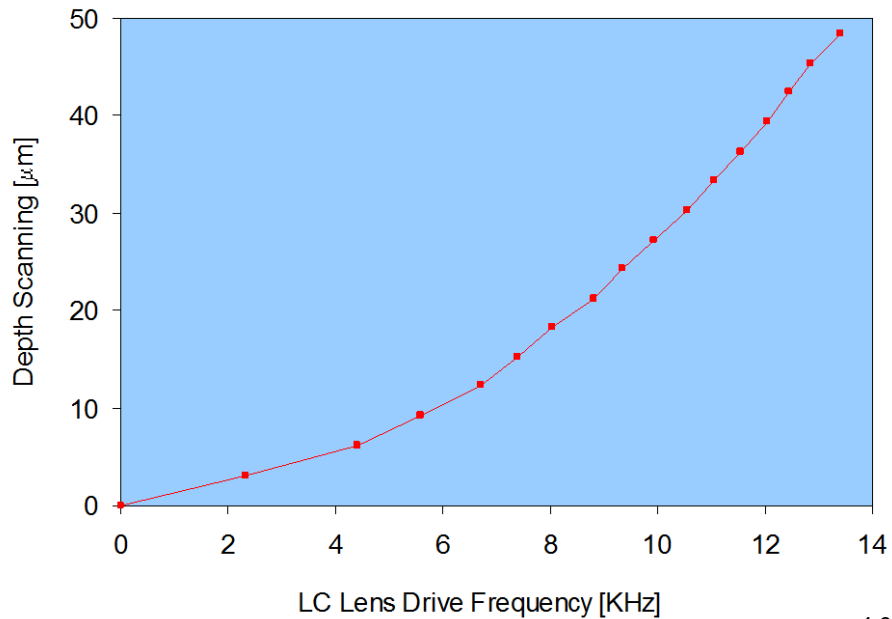

Imaging dual rectangular waveguides

Single Line scan

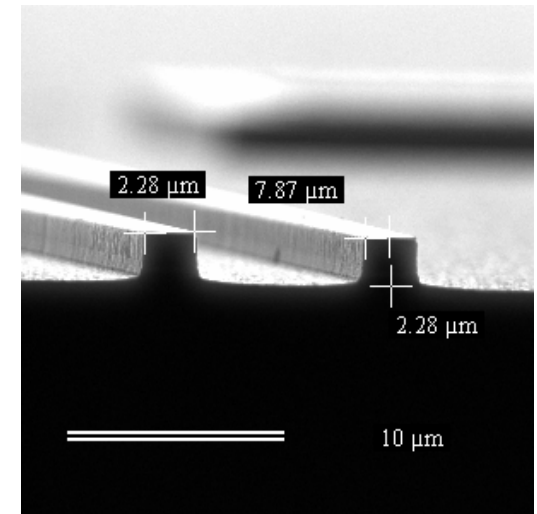
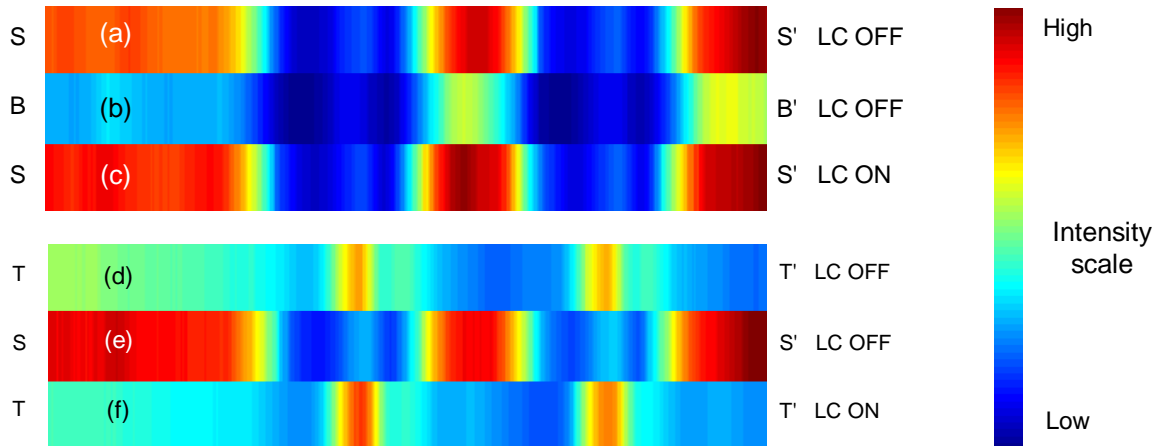
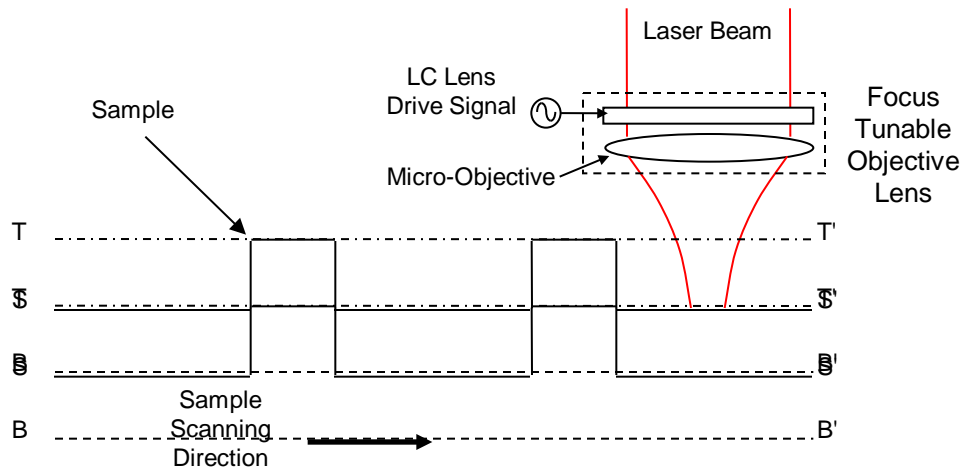

Proposed Electronic Lens-based Axial Scanning 3-D Imaging Confocal Microscope System realized by modifying a WITec Alpha-SNOM System

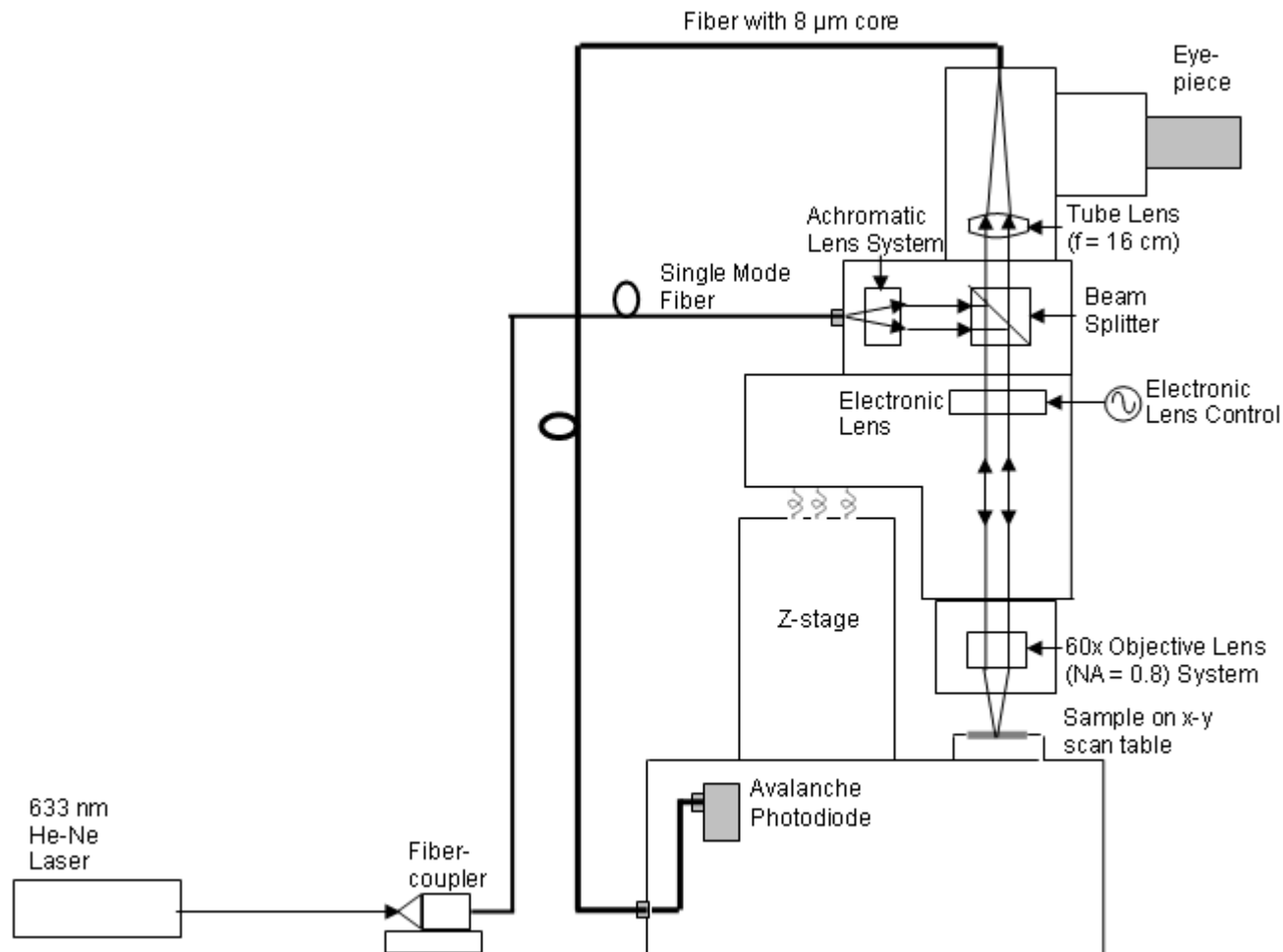

Cross-section of Artery from CDC Slide produced using Standard Optical Microscope

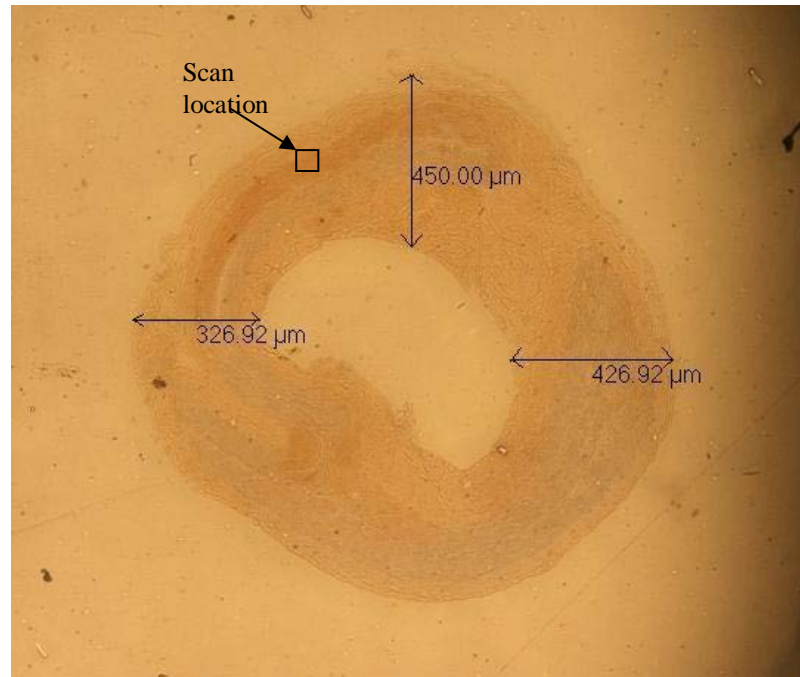

Vessel $\sim 25 \mu\text{m}$ in Axial Direction Size

White-light image using WITec microscope with a 20x objective



Scan Area: 80 μm x 80 μm

Comparative Transverse Scan Results using 20x objective

Conventional all-mechanical
scan confocal microscope

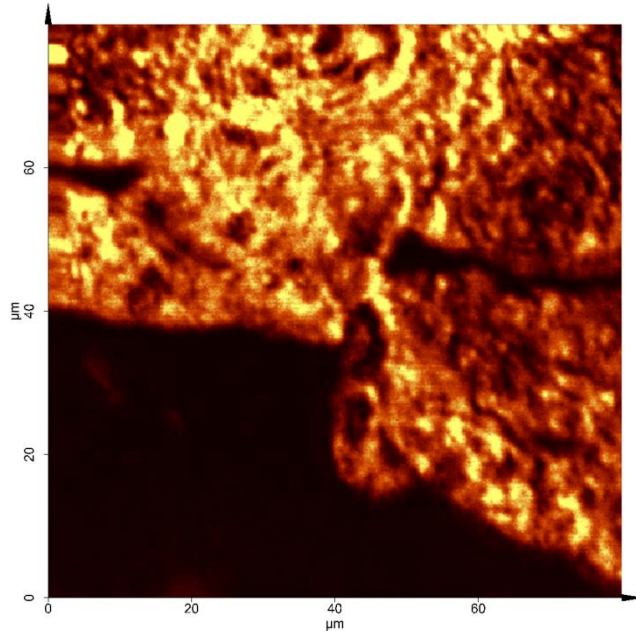

Modified confocal microscope
using LC E-lens

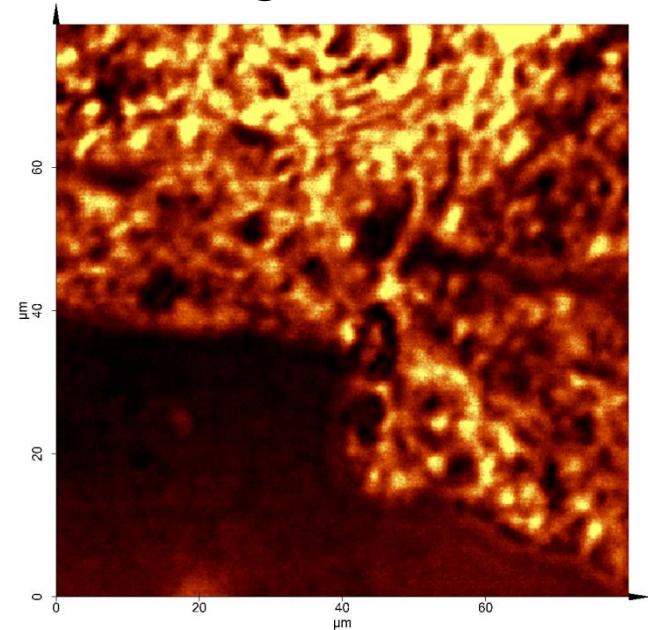

Axial Scan location $\Delta z = 0 \mu\text{m}$

Comparative Transverse Scan Results using 20x objective

Conventional all-mechanical
scan confocal microscope

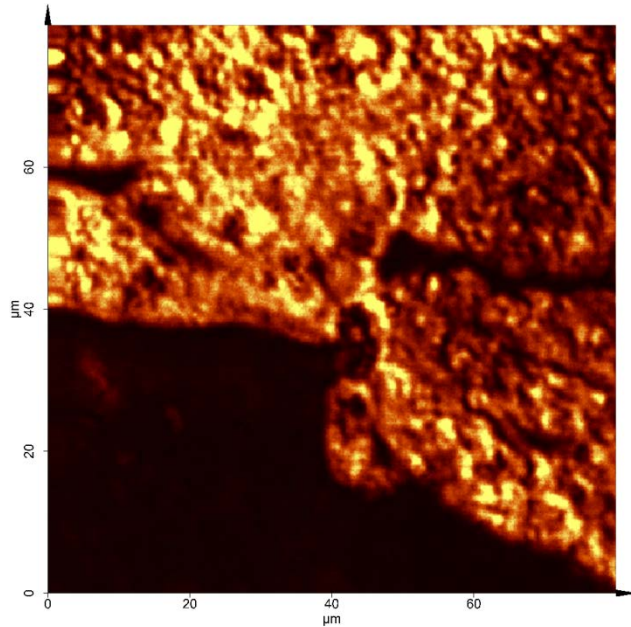

Modified confocal microscope
using LC E-lens

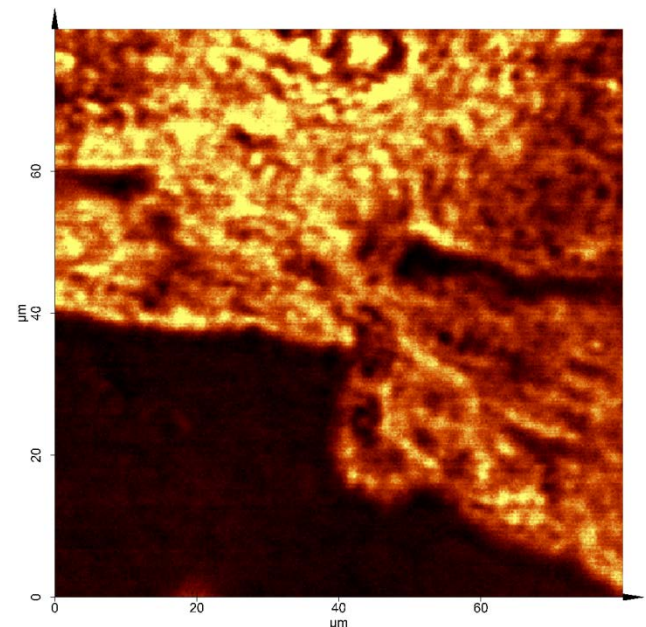

Axial Scan location $\Delta z = 5 \mu\text{m}$

Comparative Transverse Scan Results using 20x objective

Conventional all-mechanical
scan confocal microscope

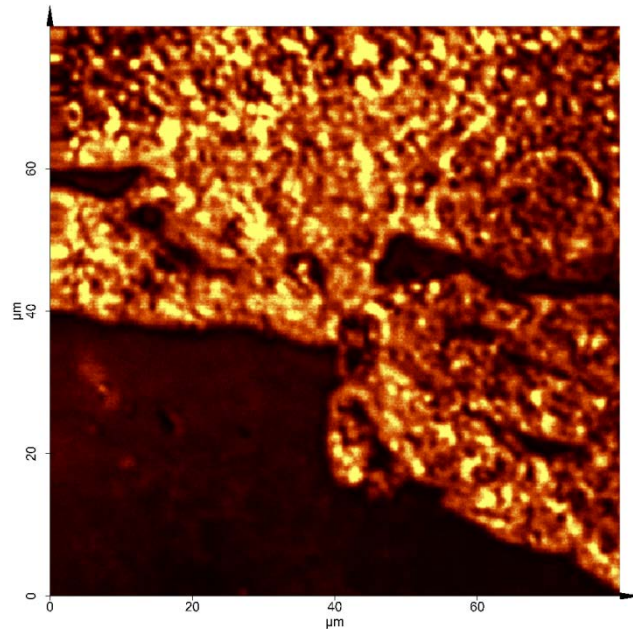

Modified confocal microscope
using LC E-lens

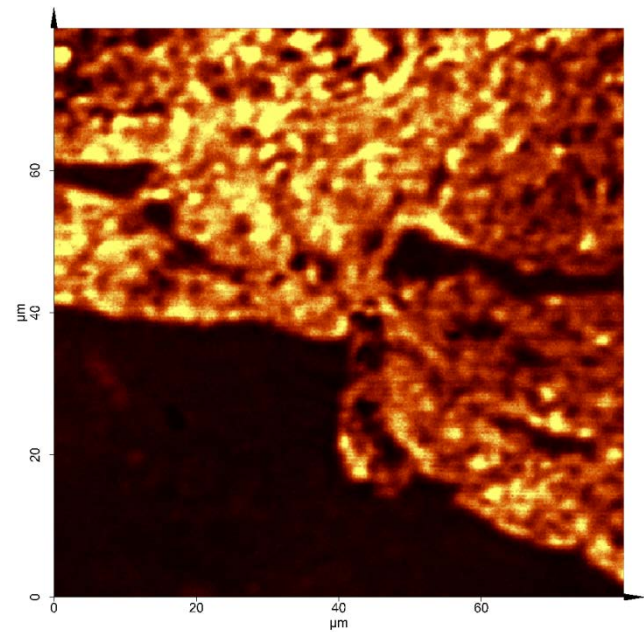

Axial Scan location $\Delta z = 15 \mu\text{m}$

Comparative Transverse Scan Results using 20x objective

Conventional all-mechanical
scan confocal microscope

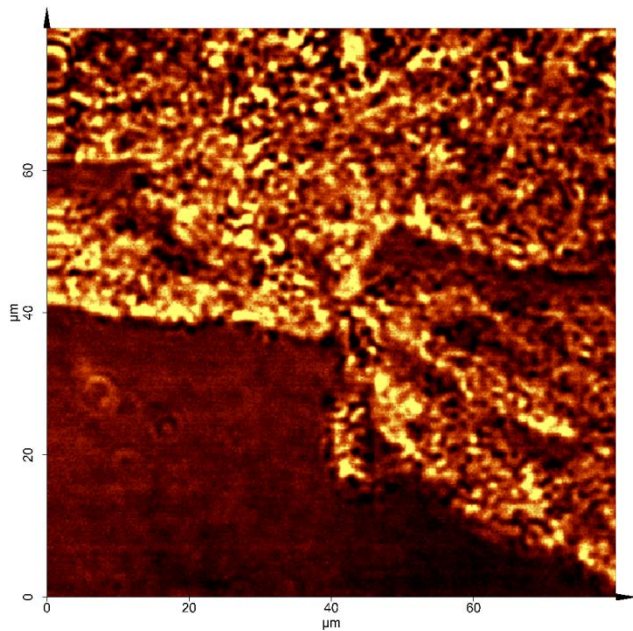

Modified confocal microscope
using LC E-lens

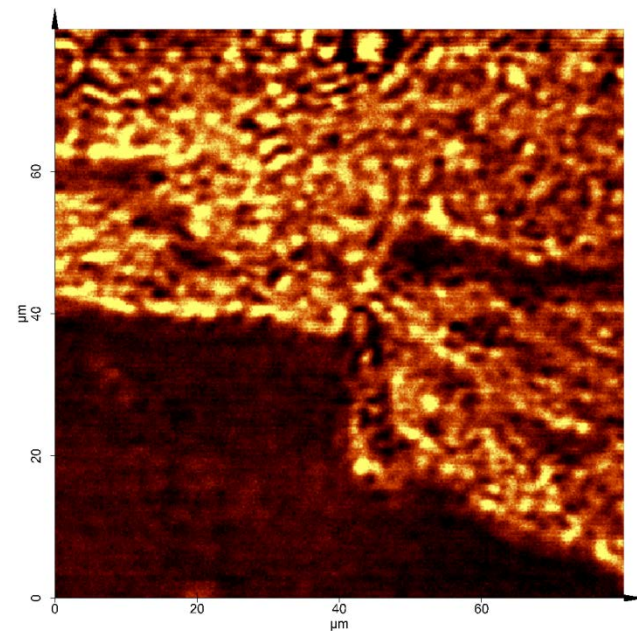

Axial Scan location $\Delta z = 25 \mu\text{m}$

Comparative Transverse Scan Results using 20x objective

- Scan area of $80\ \mu\text{m} \times 80\ \mu\text{m}$
- Transverse motion step of $0.2\ \mu\text{m}$
- Micro-objective NA=0.4

Comparative Axial Scan Results

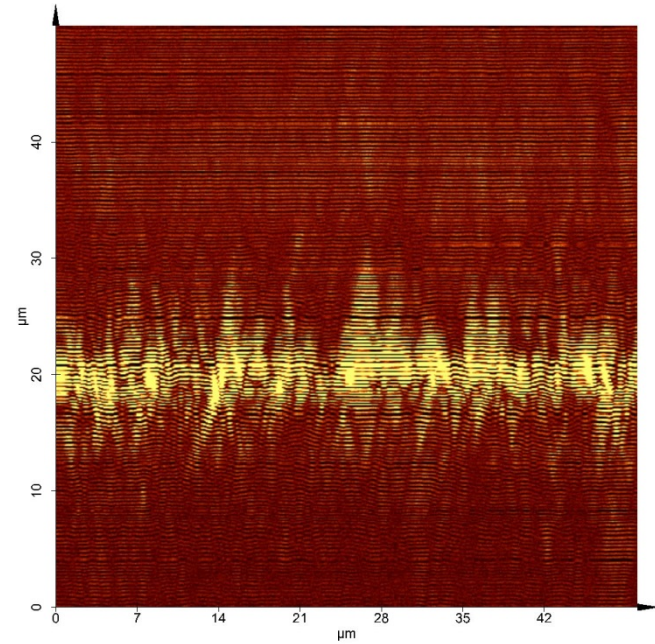
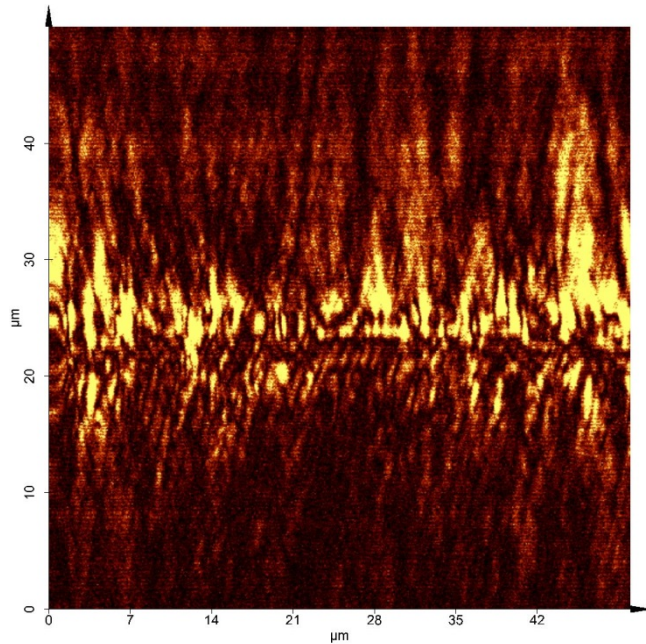

Shows a 5 μm z-displacement in the image taken using E-lens based microscope (right photo) versus no-E lens scan (left)

- Motion step = 0.1 μm in both x and z-directions
- Scan area of 50 μm x 50 μm

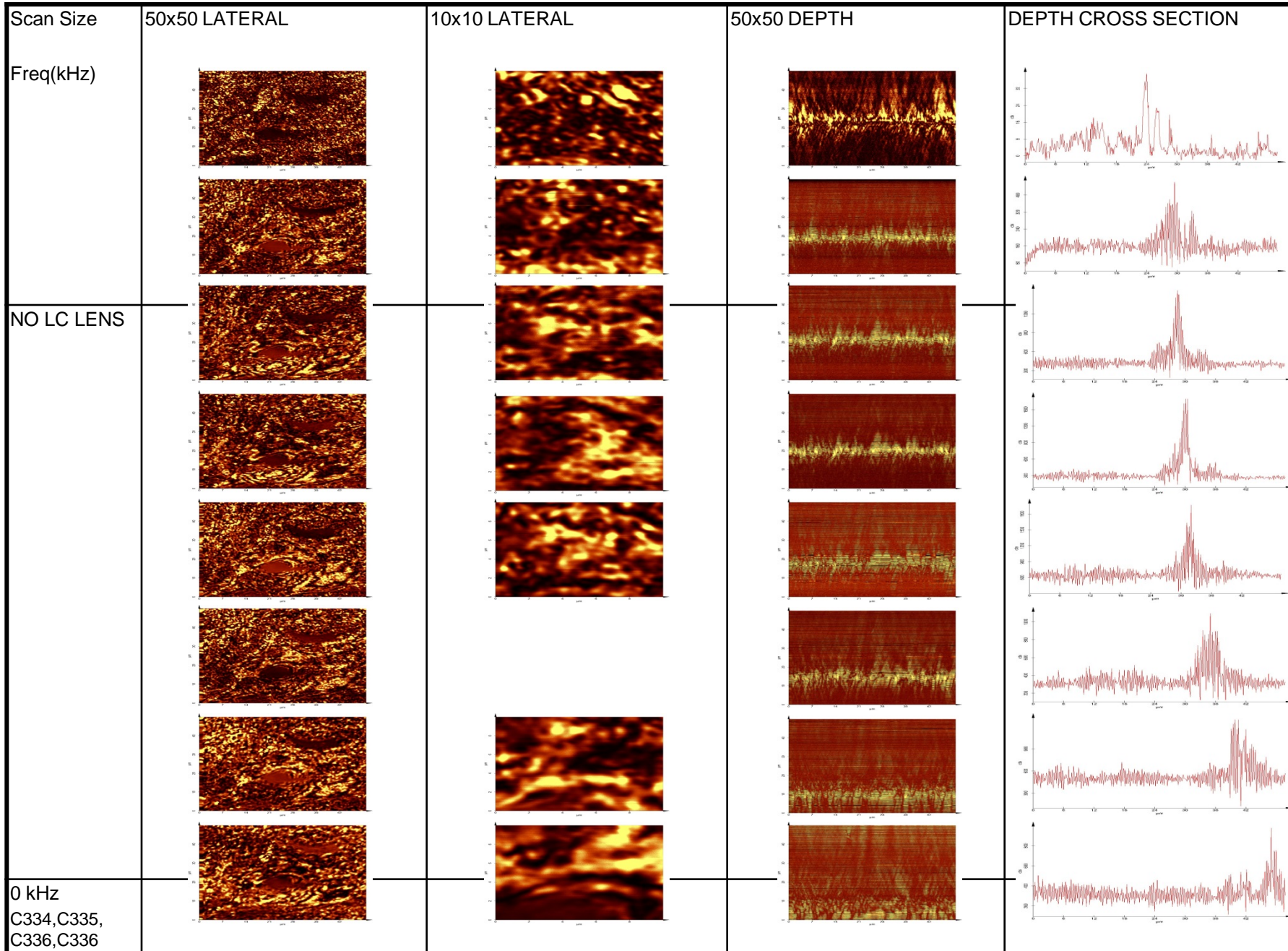

4-State Super Fast Digital Lens Demonstration in Infrared 1310 nm

Digital
Control State



00

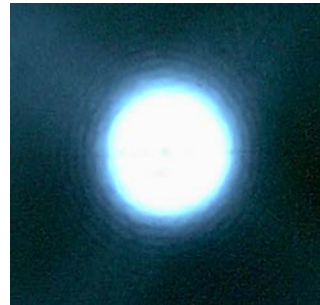

Collimated beam

01



L2 focusing

Digital
Control State



10



L1 focusing

11

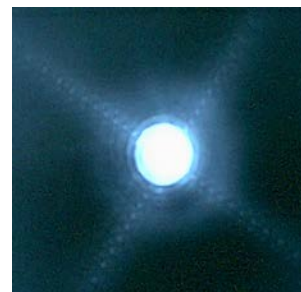

both L1 and L2
focusing

Lens Reset
Time: 10 μ s
(100 KHz)

FLC Polarization Switch Response at Infrared 1550nm Wavelength

FLC Response

FLC Drive Signal

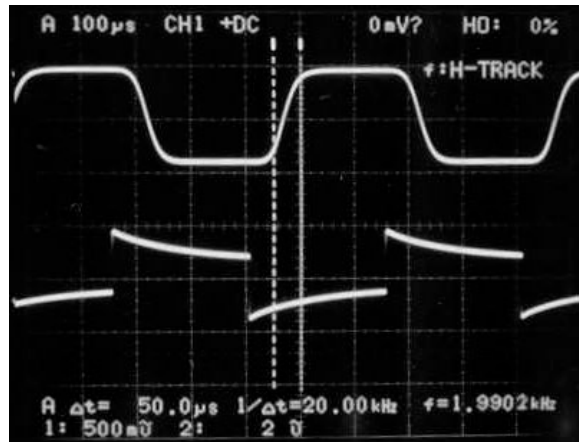

Rise Time: 50μs

FLC Response

FLC Drive Signal

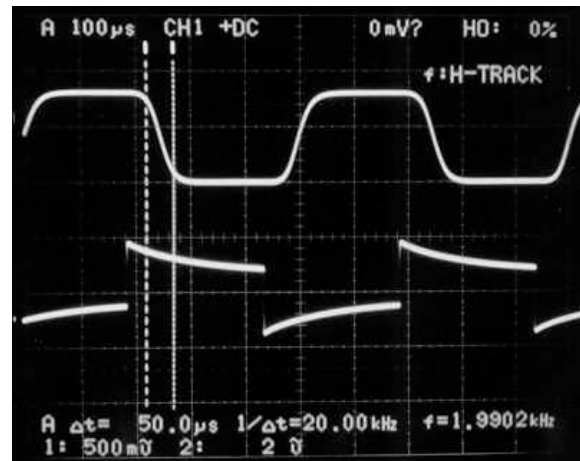

Fall Time: 50μs

High Speed Axial Scanning Confocal Microscope is Indeed Possible & The next Step
Expected Speed in Visible Spectrum: 5μs Reset Time

Confocal Microscope Resolution

Objective NA = 0.4, $\lambda=633$ nm, $n=1.4$ for skin, Magnification = 20x

$$d_{Tr} = 0.46 \frac{\lambda}{NA} = 0.73 \mu m \quad (\text{Transverse})$$

$$d_{Ax} = \frac{1.4n\lambda}{NA^2} = 7.75 \mu m \quad (\text{Axial})$$

LECTURE CONCLUSIONS

The 3-D Scanner can Greatly Impact the Fields of:

-- Non-Destructive Testing and Measurement

--Biological Monitoring and Health